



SCT040

40 lb (18 kg)

Built for Reliable Performance

Our heavy-duty construction provides reliable operation and guarantees your washer-extractor will be in service for years to come. That's why our bearings are protected against moisture with dual triple-lip seals and a stainless sleeve around the trunnion. That's why our large door design makes loading and unloading easy, while our improved door locking mechanism is designed to withstand the rigors of commercial use.

- Self cleaning four-compartment dispenser automatically dispenses detergent and fabric softener at appropriate times in the wash cycle
- Our heavy-duty construction provides reliable operation for years to come
- Industry-leading flexible water level settings will help you save on utilities
- Durable stainless steel front and top
- Quantum® gives you complete laundry control to reduce costs and increase throughput



Quantum® Control

Quantum® offers a total of 9 programmable cycles as well as 9 programmable water levels that enable you to adjust water use in every cycle step. The infrared programming and audit data retrieval save time, as do advanced diagnostics. Quantum machines feature a maximum extraction speed of 200 G-force. Quantum is designed to help you reduce costs, decrease your downtime and increase your throughput.

Hardmount Washer-Extractor

Specifications

		SCT040	
Control Option		Quantum	
Capacity - lb (kg)		40 (18)	
Overall Width - in (mm)		30.6 (777)	
*Overall Depth - in (mm)		42.3 (1074)	
Overall Height - in (mm)		47.2 (1199)	
Cylinder Diameter - in (mm)		26.3 (668)	
Cylinder Depth - in (mm)		20.3 (516)	
Cylinder Volume - cu. ft (liters)		6.3 (178)	
Door Opening Size - in (mm)		16.3 (414)	
Door Bottom to Floor - in (mm)		14.6 (371)	
Water Inlet Connection - in (mm)		2 x 0.75 (19)	
Drain Diameter - in (mm)		1 x 3 (76)	
Drain Height to Floor - in (mm)		4.5 (114)	
Motor Power Consumption - HP (kW)		2 (1.5)	
Total Number of Speeds		6,9	
Cylinder Speeds - RPM (G-Force)	Gentle	33 (0.4)	
	Wash	46 (0.8)	
	Distribution	82 (2.5)	
	Very Low	269 (27)	
	Low	464 (80)	
	Medium	518 (100)	
	High	579 (125)	
	Very High	635 (150)	
	Ultra High	733 (200)	
** Voltage Wires/ Circuit Breaker - FLA	B	120/60/1	20-15
	X	200-240/50-60/1/3	15-7 (1 Ph) 15-4 (3 Ph)
	N	440-480/50-60/3	15-3
Shipping Dimensions Approx.- in (mm)	Width	32.5 (826)	
	Depth	43.5 (1105)	
	Height	53.6 (1361)	
Net Weight - lb (kg)		540 (245)	
Shipping Weight - lb (kg)		580 (263)	
***Agency Approvals		cULus	

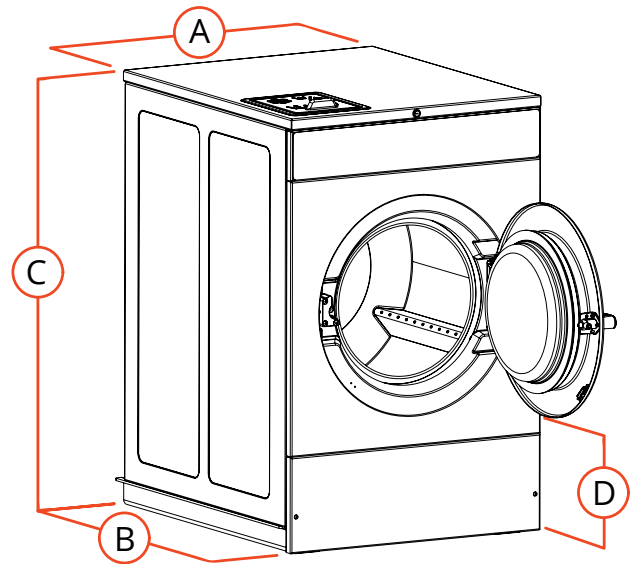

A.	Overall Width - in (mm)	30.6 (777)
B.	Overall Depth - in (mm)	42.3 (1074)
C.	Overall Height - in (mm)	47.2 (1199)
D.	Floor to Door Opening - in (mm)	14.6 (371)

* Overall depth includes vacuum breaker to door handle.

** Circuit breaker and amp draw data shown are for models without electric heat. Consult factory for other configurations. Manufacturer strongly recommends using a circuit breaker instead of fuses. Use 3-pole circuit breaker for 3-phase machines.

*** Agency approvals may vary depending on configuration. Consult factory for details. Steam connection requires 1/2" N.P.P.

For the most accurate information, the installation guide should be used for all design and construction purposes. Due to continuous product improvements, design and specifications subject to change without notice. The quality management systems at Alliance Laundry Systems are registered to ISO 9001.