



ST030  
30 lb (14 kg)

### Tumble Dryers

Our single pocket tumble dryers are designed with fewer moving parts, so that you'll face fewer maintenance problems and less wear and tear. We make it easier with a large, easy-to-clean lint compartment and a heavy-duty door hinge designed to withstand heavy usage.

- High-performance heater box increases energy efficiency, reduces drying times and provides a more comfortable operating environment.
- Precise drying performance with OPT (over-dry prevention technology).



- Large easy-to-clean lint compartment.
- Reversing option available.
- Quantum™ gives you complete laundry control to reduce costs and increase throughput.

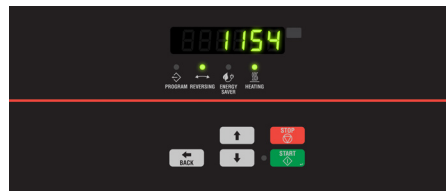

### Quantum® Control

Revolutionary Quantum® technology combines equipment controls, programming and wireless networking into one complete OPL management system, giving you total control over your laundry room from any computer, anywhere in the world. Advanced diagnostics and audit data reports help you catch errors before they become bigger issues. Quantum is designed to help you reduce costs, decrease your downtime and increase your throughput.

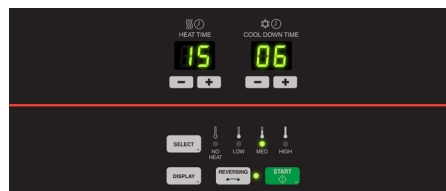

### Dual Digital Control

With features that include one-touch cycle repeat, automatic extended tumble and large digital countdown display, it's simple to set your drying time, temperature and cool down on the fly.

# Single Tumble Dryer

## Specifications

		<b>ST030</b>	
Control Option		Quantum, Dual Digital	
Capacity - lb (kg)		30 (14)	
Overall Width - in (mm)		27.9 (710)	
Overall Depth - in (mm)		45.5 (1155)	
Overall Height - in (mm)		63.9 (1625)	
Cylinder Diameter - in (mm)		26.5 (673)	
Cylinder Depth - in (mm)		30.0 (762)	
Cylinder Volume - cu. ft (liters)		9.6 (270)	
Reversing Cylinder		Standard	
Door Opening Size - in (mm)		22.7 (577)	
Heat Input Power	Gas Models - Per Pocket	73,000 Btu/hr	
	Electric Models	21kW	
Gas Connections* - in (npt)		0.5	
Air Outlet - in (mm)		6 (152)	
Motor - HP	Fan	0.5	
	Cylinder	0.3	
Airflow - cfm		500 (236)	
Electrical Specs - amps	Gas		
	B	100-120V/50/60/1	10
	X	200-240V/50/60/1/3	6
	N	440-480V/50/60/3	3
	Electric		
	D	200-208V/50/60/1	104
	E	230-240V/50/60/1	90
	F	200-208V/50/60/3	61
	G	230-240V/50/60/3	52
	K	440V/50/60/3	29
L	460-480V/50/60/3	27	
Shipping Dimensions Approx.- in (mm)	Width	30.0 (762)	
	Depth	49.0 (1245)	
	Height	67.6 (1717)	
Net Weight - lb (kg)	Gas	320 (145)	
	Electric	330 (150)	
Shipping Weight - lb (kg)	Gas	340 (155)	
	Electric	350 (160)	
Agency Approvals		CSA	

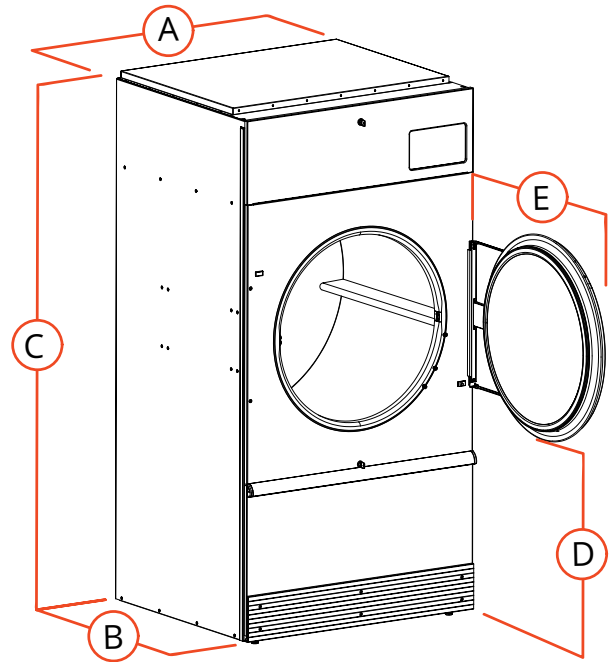

A.	Overall Width - in (mm)	27.9 (710)
B.	Overall Depth - in (mm)	45.5 (1155)
C.	Overall Height - in (mm)	63.9 (1625)
D.	Door Bottom to Floor - in (mm)	27.5 (700)
E.	Door Swing - in (mm)	26.3 (670)

\* LP gas available for 50, 75 lb capacities only. Field conversion kits available for other capacities.

Tumble dryer models are made to suit a variety of electrical service characteristics. See your Speed Queen distributor for specifications.

For further details on installation, refer to Installation, Operation and Maintenance instructions supplied with the tumble dryer. Amperage ratings available in Installation Manual.

For the most accurate information, the installation guide should be used for all design and construction purposes. Due to continuous product improvements, design and specifications subject to change without notice. The quality management systems at Alliance Laundry Systems are registered to ISO 9001.